



# Produce Plus Juicer



# For those making or consuming fresh juice anywhere in the world there are certain requirements that must be met.

## Those operating the juicer want...

- **Juice** – Good tasting, high quality juice that will turn a profit.
- **Equipment** – Safe, reliable and easy to operate equipment using minimal labor.
- **Juicing Process** – Producing acceptable juice yields at reasonable speeds.
- **Versatility** – Processes a wide variety of fruits and vegetables with minimal preparation time.

## Consumers of fresh juice expect...

- **Juice** – Fresh tasting, high quality juice at an affordable price.
- **Equipment** – Clean appearance, sanitary design, and fun to watch.
- **Juicing Process** – Eliminating unwanted seeds, peel, and excess fiber.
- **Versatility** – Delivering consistent juice quality from a wide variety of fruits and vegetables.

## Features & Benefits

- **Batch processing using whole fruits** – Saves time on labor; optimizes quality and yield.
- **Industrial Design** – Minimum down-time and maintenance costs.
- **Sanitary Design** – Easy to clean; longer shelf life of juice.
- **Completely Enclosed** – No exposed parts provides safety for operators.
- **Versatility** – Processes and blends most vegetables, fruits and tropicals.



### Processing Most Produce Varieties Like: \*

**Fruits** – Apples, Grapes, Pears, Strawberries  
**Vegetables** – Carrots, Celery, Tomato, Beets  
**Tropicals** – Pineapples, Mangos, Guava, Kiwi

**The Fresh'n Squeeze® Produce Plus Juicer provides the highest quality and highest yielding juices, using the least amount of labor.**

# Fresh'n Squeeze<sup>®</sup> Produce-Plus Juicer

## Technical Specifications

(metric shown in brackets)

Throughput .....	15 lbs. (6.8 kg)...4-5 minutes
Fruit Hopper Capacity .....	12-15 lbs. (5.4-6.8 kg)
Processing Capacity .....	48-60 quarts (45-56 liters) per hour
Reservoir Capacity .....	5 Quarts (4.7 liters)
Juicer Dimensions.....	Height 63-1/2" (162 cm)...Width 24" (61 cm)
	Depth 29" (74 cm)...Weight 350 lbs. (158.7 kg)
Shipping Dimensions .....	Height 73" (186 cm)...Width 30" (76 cm)
	Depth 36" (91 cm)...Weight 375 lbs. (170 kg)
Electrical Requirements (USA) .....	115 volts...60 Hz...20 amp service...single phase
Electrical Requirements (Export Models).....	110/220 volts...50/60 Hz 20/10 amps service...single phase
	(Dedicated Circuit Required)
Safety Features .....	Completely enclosed, safety interlock switches
Finish .....	High impact, flame retardant ABS
Weight.....	535 lbs. (243 kg)...Shipping Wt. 570 lbs. (259 kg)
Waste Container Holds .....	40 lbs. (18 kg)
Fruit Size.....	No restrictions (up to pineapple size)

**\* Not recommended for citrus fruit due to high peel oil content. Not recommended for melons due to high pH level. Remove stones and pits in stone fruits first. Kiwi, mango and pineapple must be peeled first.**

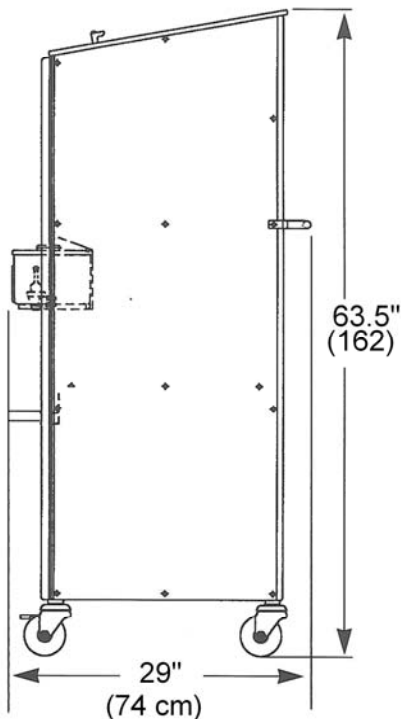

**SIDE VIEW**  
Outside Dimensions

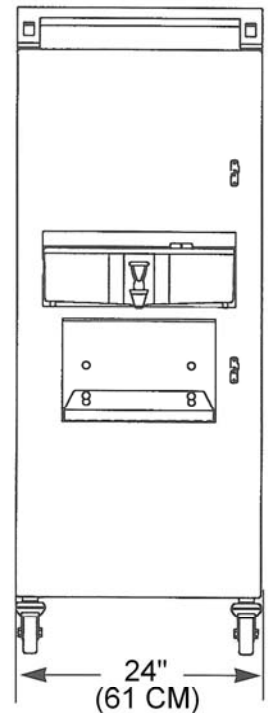

**FRONT VIEW**  
Outside Dimensions

Copyright © John Bean Technologies Corporation 2008

Mulligan Associates, Inc.  
286 Barbados Drive  
Jupiter, FL 33458  
800.627.2886  
www.juicernet.com